



Morgan Lewis

THE FUTURE OF MOBILITY FROM ESCOOTERS TO ROBOTIC SKELETONS

Lucy Wang
Kevin Benedicto

May 14, 2020

The Future of Mobility

Section 01 – Introductions

Section 02 – Mobility in a Global Pandemic

Section 03 – On the Road

Section 04 – Below the Road

Section 05 – Above the Road

Section 06 – Way Above the Road

Section 07 – Anywhere and Everywhere

SECTION 01

INTRODUCTIONS



Today's Presenters



Lucy Wang

San Francisco

Tel +1.415.442.1132

lucy.wang@morganlewis.com



Kevin Benedicto

San Francisco

Tel +1.415.442.1340

kevin.benedicto@morganlewis.com

SECTION 02

MOBILITY IN A GLOBAL PANDEMIC



Tracking Mobility

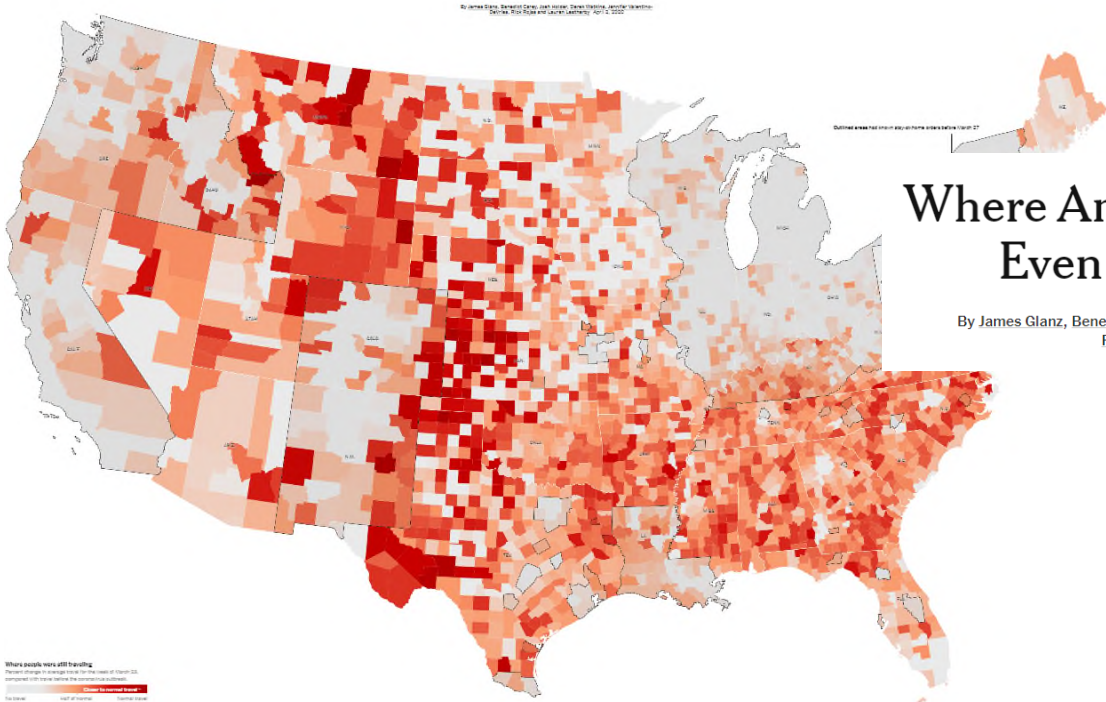

Where America Didn't Stay Home Even as the Virus Spread

By James Glanz, Benedict Carey, Josh Holder, Derek Watkins, Jennifer Valentino-DeVries, Rick Rojas and Lauren Leatherby April 2, 2020

Limiting Mobility

How Digital Contact Tracing Slowed Covid-19 in East Asia

by [Yasheng Huang](#), [Meicen Sun](#) and [Yuze Sui](#)

April 15, 2020

...

downloaded app in Korea. A vibrant democracy that has also won praise for its Covid-19 containment, Taiwan is believed to be the first to have used mobile phone tracking to enforce quarantines, which the government reportedly reinforces by calling those in quarantine twice a day to ensure they do not evade tracking by leaving their phones at home.



Tracing Mobility

NO TRACE

How Bluetooth could unleash the world's largest experiment in digital contact tracing

3 hours ago



By Amrita Khalid & Amanda Shendruk



Guiding Mobility

Electrical worker safety startup launches a COVID-19 workplace distance and contact tracker

Darrell Etherington



SECTION 03

ON THE ROAD



Stranger Than Fiction



Car Free Sections of Cities



SF Environment @SFEnvironment

Historic day in #SF 🙌. Market Street is officially car-free!
#MarketStreet2020



London Breed

12:07 PM · Jan 29, 2020 from Embarcadero Plaza · Twitter for iPhone



Times Square crowded and empty

Barcelona's Super-Blocks

Road hierarchy in a Superblock model

CURRENT SITUATION

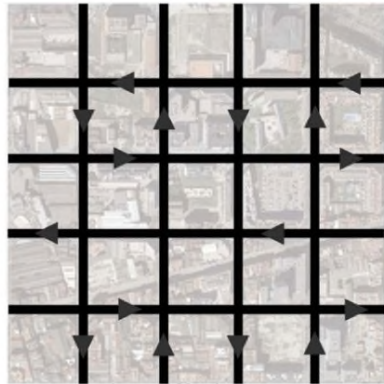

400 meters

Basic network: 50 km/h



SOLE RIGHT: DISPLACEMENT.
HIGHEST AIM: PEDESTRIAN.

SUPERBLOCK

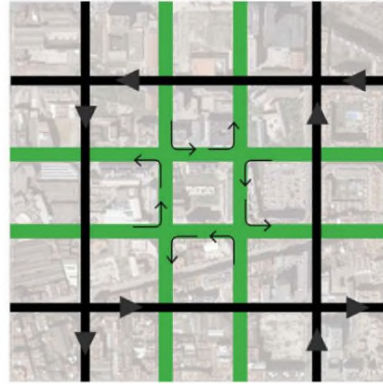

400 meters

Local network: 10 km/h



EXERCISE OF ALL THE RIGHTS THAT THE CITY
OFFERS. HIGHEST AIM: CITIZEN.

PASSING
VEHICLES
DO NOT GO
THROUGH



Council of Chelsea Block Associations et al v. Trottenberg

FILED: NEW YORK COUNTY CLERK 06/20/2019 04:35 PM INDEX NO. 156133/2019
NYSCEF DOC. NO. 1 RECEIVED NYSCEF: 06/20/2019

SUPREME COURT OF THE STATE OF NEW YORK
COUNTY OF NEW YORK
----- X

In the Matter of

COUNCIL OF CHELSEA BLOCK ASSOCIATIONS,
William Borock, President;
FLATIRON ALLIANCE, INC., Michele Golden & Susan
Finley, Co-Directors;
WEST 12th STREET BLOCK ASSOCIATION, Marguerite
Martin, Co-Chair;
UPPER WEST 13th STREET BLOCK ASSOCIATION, INC.,
Jeffrey Ryan, President;
WEST 13th STREET 100 BLOCK ASSOCIATION, INC.,
Gary Tomasi, President;
100/200 WEST 15th STREET BLOCK ASSOCIATION,
Steven Starosta & Kimon Rezon, Co-Chairs;
100 WEST 17th & 18th STREETS BLOCK ASSOCIATION,
Judy Klein And Michael Glasman, Co-Presidents;
16th STREET TENANTS CORP., Sherrie Levy, President;
13 WEST 13th APARTMENT CORPORATION; Michael
Cohen, President;
CAMBRIDGE OWNERS CORPORATION, Trevor Stewart,
President;
VICTORIA OWNERS CORPORATION, James Heller,
Treasurer;
VERMEER OWNERS, INC.,
JOHN WETHERHOLD;
DAVID R. MARCUS;
JULIANNE BOND; and
ARTHUR Z. SCHWARTZ, individually and as Male
Democratic District Leader for the 66th Assembly District
Part A,
Petitioners,

--against--

POLLY TROTTEMBERG, as COMMISSIONER OF THE
CITY OF NEW YORK DEPARTMENT OF
TRANSPORTATION,
Respondent,
----- X

For an Order and Judgment Pursuant to Article 78 of the
Civil Practice Law and Rules, the State Environmental Quality
Review Act, and the New York City Environmental Quality
Review Act.

----- X

1 of 39

“DOT has come up with a new ‘rationale’ for the Corridor Plan, since the original rationale was no longer viable,” the suit alleges. “That rationale (making bus service faster) amounts to no more than PR material. The result, Petitioners contend, will be increased vehicular traffic on all east and westbound streets between 12th Street and 20th Street, bringing with it air pollution, noise, and vibrations endangering the 19th century buildings which line these blocks, challenging the character of the Greenwich Village, Chelsea, and Flatiron communities, and likely causing delay in the crosstown transit of emergency vehicles.”

Other Challenges and Legal Implications

- Cooperation between government agencies and developers
- Regulatory hurdles
- Unintended secondary effects of congestion
- Safety risks when transitioning out of pedestrian zones
- Pushback from businesses and transportation companies

Scooters and Bikes – Tremendous Growth



SPIN



Industry Developments Due to COVID-19

In Italy, we've lent some scooters to the **Croce Rossa Italiana** in Rimini, so they can deliver medicine quickly to residents. [...see more](#)



Even during a pandemic, life doesn't stop. People still need to go places, whether they're medical personnel working the [...see more](#)



Lime Aid Brings Safe Essential Services For Cities, Free Rides To Health Care Workers...

San Francisco Case Study

SAN FRANCISCO
MUNICIPAL TRANSPORTATION AGENCY
BOARD OF DIRECTORS

RESOLUTION No. 190716-098

WHEREAS, In May 2018, the SFMTA Board of Directors approved changes to the Transportation Code, Division II, to establish the Powered Scooter Share Pilot Program (Pilot); and,

WHEREAS, The SFMTA reviewed 12 applications and granted two 12-month permits to the strongest applicants effective October 15, 2018-October 14, 2019; SFMTA staff released a Mid-Pilot Evaluation in April 2019 to the Board of Directors summarizing key findings including that the Pilot yielded notable public benefits as a useful component of San Francisco's transportation system; and,

WHEREAS, The proposed Transportation Code revisions amend the Transportation Code, Division II, to modify existing Powered Scooter Share Permit Program requirements to, among other things, remove the limitations of the pilot program, authorize the Director to determine the appropriate number of permitted scooters and permittees, require that powered scooters have integrated lock-to devices, revise distribution and rebalancing requirements, update data sharing terms, adjust the permit fee schedule and endowment fund amounts, revise the fine structure for parking violations as between permittees and non-permittees, require a more robust community engagement process, and require that applicants provide sample scooters for inspection and evaluation by the SFMTA; and,

Project Timeline

June - August 2018

October 2018 - October 2019

October 15, 2019

Agency Review of Scooter

Pilot Program

Permit Program Begins

Applications



SFMTA Powered Scooter Share Program Permit Application

The Powered Scooter Share Program Permit allows permitted Powered Scooter Share Operator to operate a Powered Scooter Share Program in the City and County of San Francisco. The SFMTA shall implement this Program consistent with the SFMTA's "Guiding Principles for Emerging Mobility Services and Technologies" and Transportation Code, Div. II, Section 916.

The SFMTA will review the completed applications, determine whether each applicant conforms to the SFMTA's requirements, and evaluate applications according to the scoring criteria described in this application. The SFMTA anticipates issuing a limited number of Powered Scooter Share Program permits in consideration of maintaining clarity and usability for customers, and ease of program administration.

Applicant Information

Business Name		Please Print Clearly	
Contact Person	Business Phone	Phone	
Mailing Address			
Street Address if different than above			
Email Address	Website		

Application Agreement

By signing this application, the applicant verifies on behalf of the Powered Scooter Share Operator that all the information provided is true and accurate; that if issued a permit, the applicant agrees to comply with the Permit Requirements in Appendix A, without change to its terms and conditions, and any other requirements of the Powered Scooter Share Program Permit as issued; and, further, that the applicant agrees that all submitted documents and materials, and their contents, are subject to public review, and that no documents or other materials provided to the SFMTA will be considered confidential or otherwise withheld from public disclosure if requested after the deadline for submitting applications has passed.

Name of Applicant
Authorized Signature
Printed Name, Title and Date

SFMTA Powered Scooter Share Program Permit Application

Table of Contents

Submission Instructions	2
Question and Answer Session	2
Permit Costs	2
Application Materials	3
A. Device Standards and Safety Assurances	3
B. Sample Scooters	3
C. Pricing Structure	4
D. Operations Plan	4
E. Plan for Safe Scooter Riding & Parking	5
F. Recharging, Maintenance, Cleaning, and Sustainability Plan	6
G. Hiring and Labor Plan	7
H. Community Engagement Plan	8
I. Data-Sharing End Point	8
J. Experience and Qualifications	8
K. Privacy Policy, User Agreements, and Terms of Service	8
L. Images and Description of Powered Scooter	9
M. Images and Description of Mobile Application	9
N. Proof of Insurance	9
Scoring	9
Appendices and Related Documents	10
Appendix A. Permit Requirements	11
General Requirements	11
Program Requirements	11
Operating Requirements	12
Equitable Service Requirements	12
Distribution of Scooters	13
Responsiveness Requirements	14
Device Requirements	15
Safe Riding and Storage of Scooters	15
Endowment and Fees	15
Data-Sharing Requirements	16
Privacy Policy	17
Permit Revocation	18
Compliance with Applicable Law	18
Payment of Fees	19
Removal of Improperly Parked Scooters	19
Permit Jurisdiction	19
Appendix B. Insurance and Indemnification Requirements	20
Indemnification	20
Insurance Requirements	20

© 2019 San Francisco Municipal Transportation Agency. All rights reserved. For more information, visit www.sfmta.com. This document is the property of the SFMTA and is not to be distributed outside the SFMTA. Printed on recycled paper.

Statewide Regulation – New York State

E-Bikes and E-Scooter Rentals Won't Be Allowed in N.Y. Anytime Soon

Gov. Andrew Cuomo vetoed a bill that would have legalized both types of transport, angering supporters of the measure.

NEW YORK MINUTE

E-bike, e-scooter legislation gets a second chance in New York

Plus, "Bird God" vandal strikes the Grand Army Plaza arch again—and more intel in today's New York Minute news roundup

By **Caroline Spivack** | Jan 24, 2020, 10:30am EST

TECH \ TRANSPORTATION \ RIDEABLES \

New York finally legalizes electric bikes and scooters

A huge win for immigrant delivery workers

By **Andrew J. Hawkins** | [@andyjayhawk](#) | Apr 2, 2020, 11:38am EDT

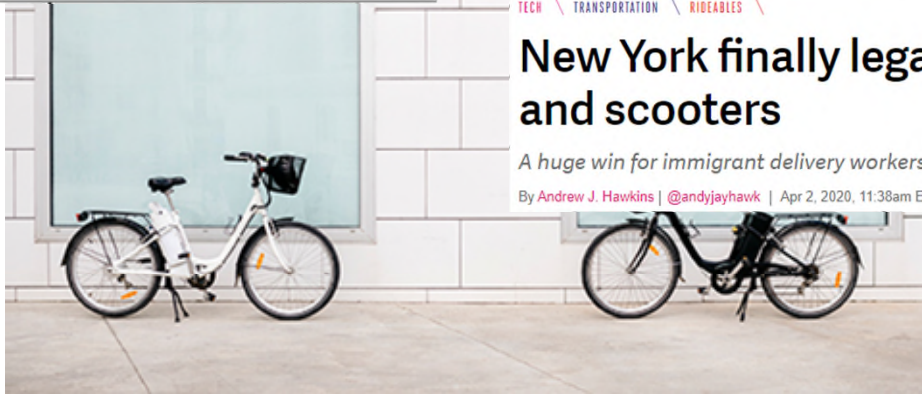

Scooters and Bikes – Other Legal Implications

- Municipal Regulations and Exclusivity Agreements
- Environmental Regulations and Impact
- Labor and Employment Issues
- High M&A Activity
- Liability/Personal Injury Issues

SECTION 04

BELOW THE ROAD



Concept – Virgin Hyperloop One

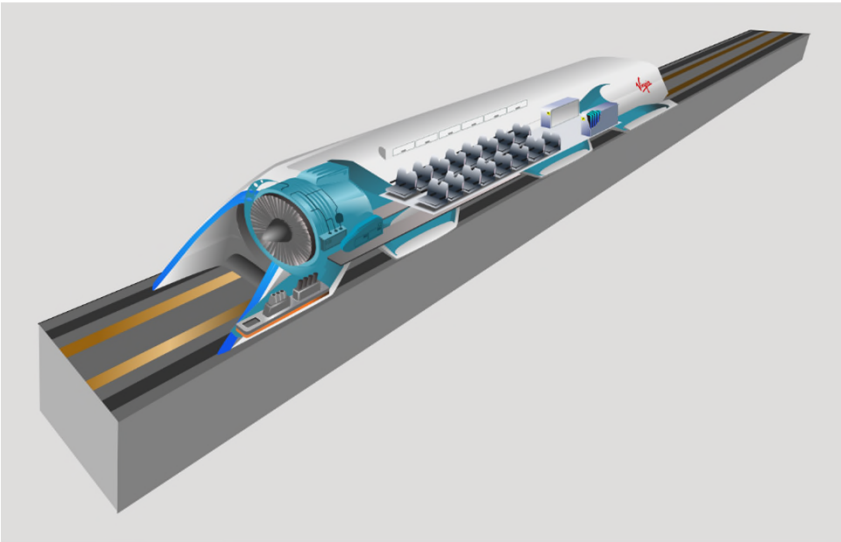

- New proposed method of transportation.
- Passengers or cargo are loaded into the hyperloop vehicle and accelerate gradually via electric propulsion through a low-pressure tube. The vehicle floats above the track using magnetic levitation and glides at airline speeds for long distances due to ultra-low aerodynamic drag.
- Active development since 2013.

Source: Virgin Hyperloop One & Hyperloop Transportation Technologies

How Fast is Hyperloop?

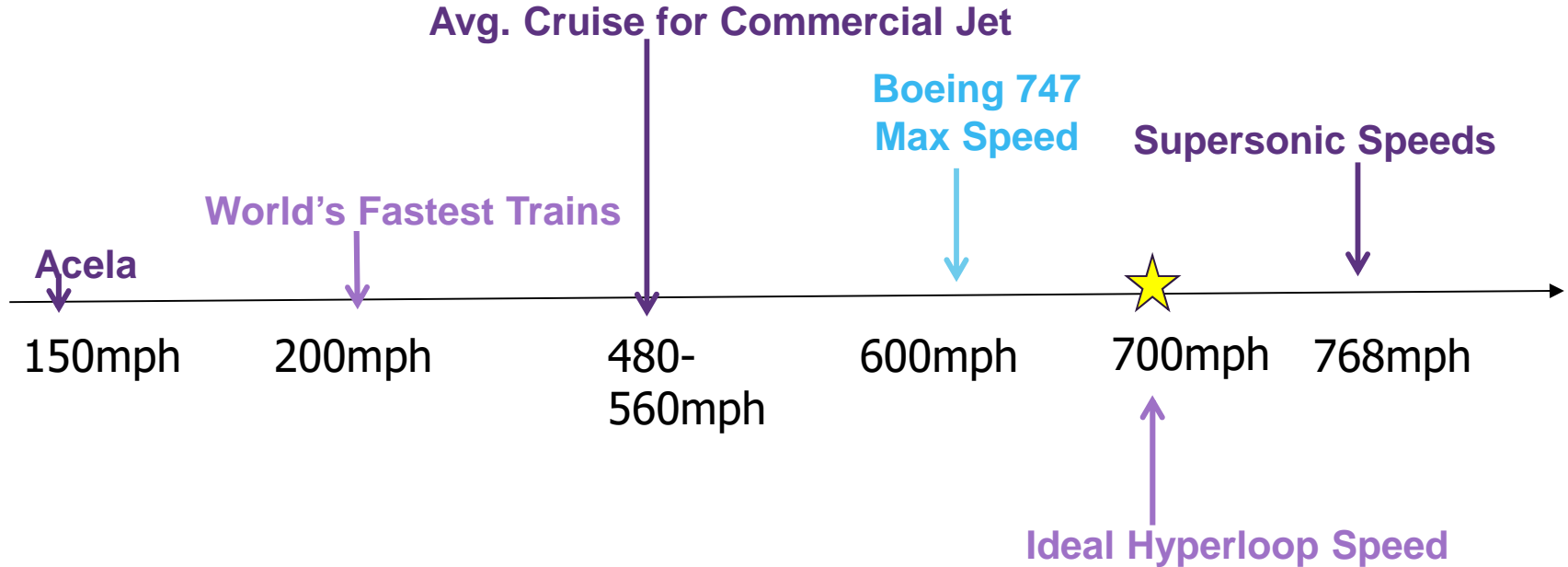

Who is Developing Hyperloop?

Virgin hyperloop one

SPACEX

HYPERLOOP
TRANSPORTATION TECHNOLOGIES



Boring Company and Urban Tunneling



Photos: The Boring Company

Lawsuits to Stop Tunneling



MICHAEL N. FEUER
CITY ATTORNEY

REPORT NO. R 18 - 0135
MAY 15 2018

REQUEST FOR CLOSED SESSION PURSUANT TO
GOVERNMENT CODE SECTION 54956.9(d)(1)

REPORT RE:

STATUS OF PENDING LITIGATION

BRENTWOOD RESIDENTS COALITION ET AL V. CITY OF LOS ANGELES
LASC CASE NO. BS173523 - COUNCIL FILE 17-1342-S1
(COUNCIL DISTRICTS 5 AND 11)

The Honorable City Council
of the City of Los Angeles
Room 395, City Hall
200 North Spring Street
Los Angeles, California 90012

Honorable Members:

This Office recommends that discussion with, and advice from, legal counsel with respect to this pending litigation be scheduled and held in closed session pursuant to California Government Code Section 54956.9(d)(1). Government Code Section 54956.9 requires you to state publicly, prior to the closed session, what division of this section authorizes the closed meeting, and that the closed session is being held to confer or discuss with, or receive advice from, legal counsel regarding pending litigation.

This matter involves a proposed tunnel excavation permit for the Boring Company's Proof of Concept Tunnel Project.

City Hall East 200 N. Main Street Room 800 Los Angeles, CA 90002 (213) 978-8400 Fax (213) 978-8332

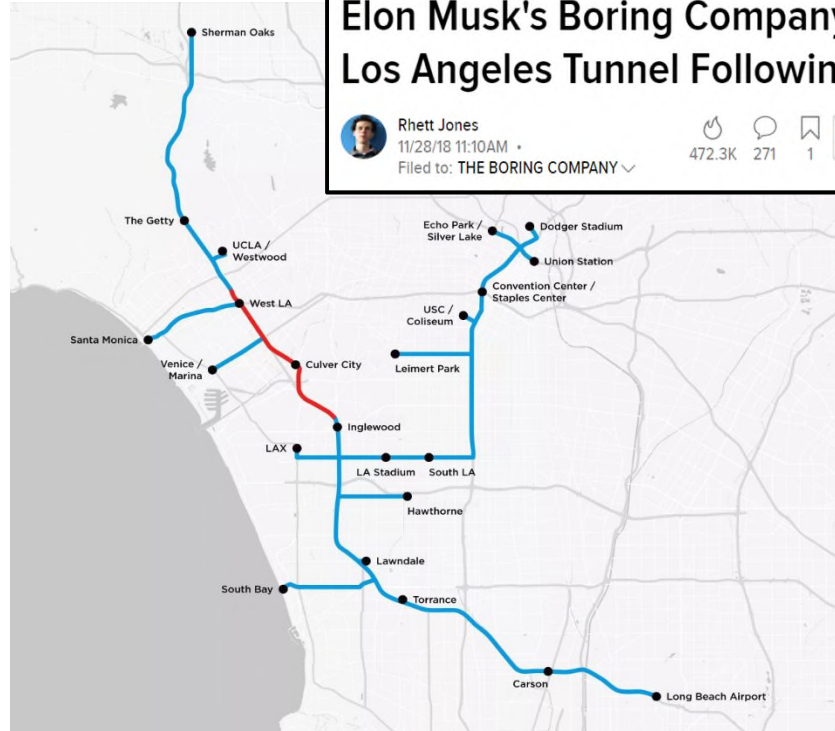

NEWS

Elon Musk's Boring Company Cancels Los Angeles Tunnel Following Lawsuit



Rhett Jones

11/28/18 11:10AM

Filed to: THE BORING COMPANY



472.3K



271



1



Lawsuits to Stop Tunneling



MICHAEL N. FEUER
CITY ATTORNEY

REPORT NO. R 18 - 0135
MAY 15 2018

REQUEST FOR CLOSED SESSION PURSUANT TO
GOVERNMENT CODE SECTION 54956.9(d)(1)

REPORT RE:

STATUS OF PENDING LITIGATION

BRENTWOOD RESIDENTS COALITION ET AL V. CITY OF LOS ANGELES
LASC CASE NO. BS173523 - COUNCIL FILE 17-1342-S1
(COUNCIL DISTRICTS 5 AND 11)

The Honorable City Council
of the City of Los Angeles
Room 395, City Hall
200 North Spring Street
Los Angeles, California 90012

Honorable Members:

This Office recommends that discussion with, and advice from, legal counsel with respect to this pending litigation be scheduled and held in closed session pursuant to California Government Code Section 54956.9(d)(1). Government Code Section 54956.9 requires you to state publicly, prior to the closed session, what division of this section authorizes the closed meeting, and that the closed session is being held to confer or discuss with, or receive advice from, legal counsel regarding pending litigation.

This matter involves a proposed tunnel excavation permit for the Boring Company's Proof of Concept Tunnel Project.

City Hall East 200 N. Main Street Room 800 Los Angeles, CA 90002 (213) 978-8100 Fax (213) 978-8332

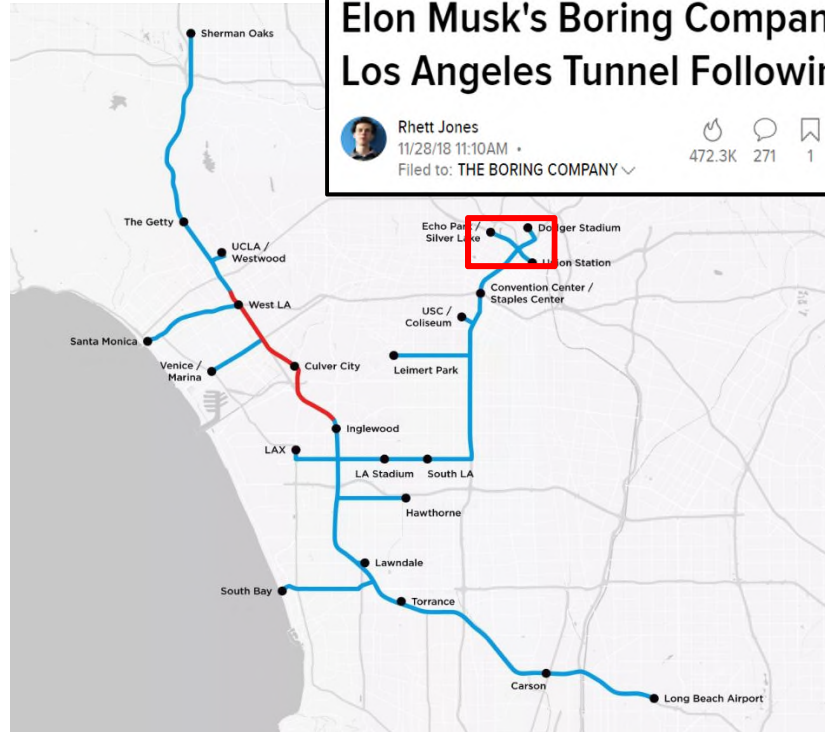

NEWS

Elon Musk's Boring Company Cancels Los Angeles Tunnel Following Lawsuit



Rhett Jones

11/28/18 11:10AM

Filed to: THE BORING COMPANY



472.3K



271



1



SECTION 05

ABOVE THE ROAD



Jetpacks

Own the Sky: David Mayman launches jetpack documentary with thunderous public flight demo



Flying Taxis



Jan. 16, 2020

Toyota and Joby Aviation are Flying to New Heights Together

Boeing Partners with Porsche

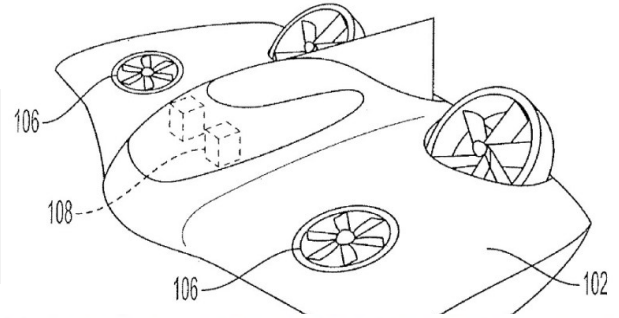

Bell and Hyundai Soar Into the Air Taxi Race

At CES, the helicopter maker and the global manufacturing giant unveil their concepts for flying urban mobility.



Flying Taxis



'GoFly' Fly-Off Showcases the Future of Personal Flight

By David Cardinal on March 2, 2020 at 10:02 am | [6 Comments](#)

Wisk strikes a deal to conduct a flying taxi trial in New Zealand

Wisk is a joint venture between Boeing and Larry Page's Kitty Hawk

By [Andrew J. Hawkins](#) | [@andyjayhawk](#) | Feb 4, 2020, 11:57am EST

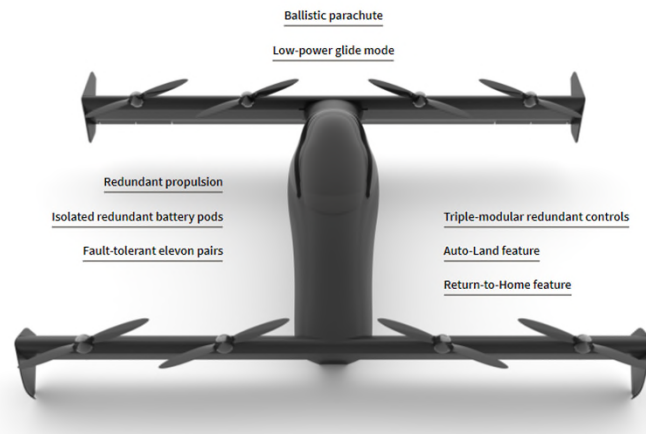

Flying Taxis

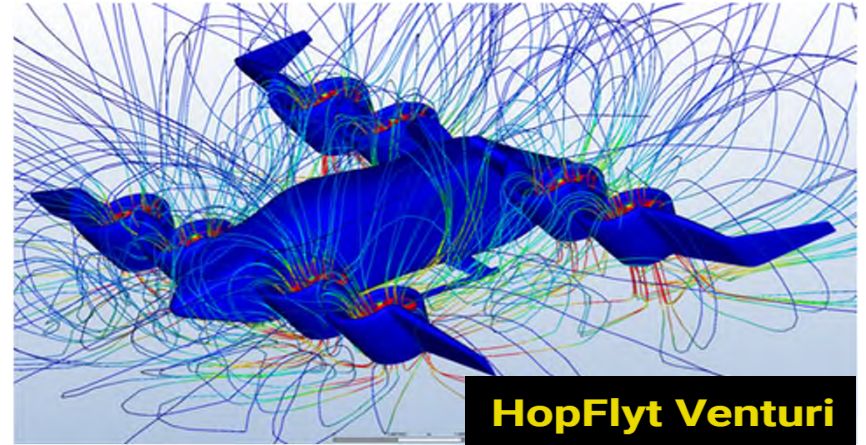

White House: 2021 R&D Budget Priorities

Policy Memorandum M-19-25

Office of Science & Technology Policy (August 30, 2019)

American Leadership in Industries of the Future

*The Trump Administration continues to prioritize the technologies that power Industries of the Future (IoF) . . . Departments and agencies should support the development and deployment of advanced communications networks by prioritizing R&D consistent with the National Spectrum R&D Strategy. They should prioritize R&D to lower barriers to the deployment of surface, air, and marine autonomous vehicles with a focus on developing operating standards, integration approaches, traffic management systems, and defense/security operations. **Departments and agencies should prioritize R&D that enables electric vertical-takeoff-and-landing** and civil supersonic aircraft, including for type certification, the creation of over-land supersonic flight noise standards, and low-sonic-boom aircraft research.....*

NASA: UAM Grand Challenge

Grand Challenge Will Bring NASA, FAA And Industry Together On UAM

NASA / FAA (September 18, 2019)

Our next step for realizing UAM begins in 2020 with preparations for a series of activities called the Grand Challenge.

The Grand Challenge series will offer something more valuable than a prize purse – valuable knowledge that will be given to the organizations working to establish the certification requirements and standards needed for the market to move forward.

It's about promoting public confidence in advanced air mobility systems, and helping organizations and companies learn what it really takes to operate air vehicles safely in an urban environment.

Air Force: Agility Prime

- The Air Force recently launched Agility Prime, a non-traditional program seeking to accelerate the commercial market for advanced air mobility vehicles
- Agility Prime aims to bring together industry, investor, and government communities to establish safety and security standards while accelerating commercialization of this revolutionary technology.
- The Innovative Capabilities Opening establishes a rapid contracting mechanism beginning in 2020 with a “Race to Certification” series to drive government procurement of operational capability by 2023.

FAA: “[W]e’re out in front with urban air mobility”

Daniel Kevin Elwell, Acting Administrator, FAA

Uber Elevate Urban Air Mobility Summit 2019 (June 11, 2019)

We learned that the hard way when UAS technologies and an entirely new industry sprung up practically overnight and we weren’t ready for it.

We’re sort of caught up now, but we are also determined not to let it happen again.

That’s why we’re out in front with urban air mobility, or UAM, working with the industry and with NASA to make sure we get it right.

FAA: “Yes, this is more than just hype.”

Jay Merkle, Executive Director, UAS Integration Office, FAA
Transportation Research Board (January 13, 2020)

*I want to close with some thoughts on the next very, very innovative piece of technology that we see emerging, and that’s urban air mobility. . . . And probably the biggest question I get on this is, is this real? Are they really happening? Yes, this is more than just hype. This is more than just promotional videos. **We have at least six aircraft well along in their type certification**, which is the first step in introducing the new aircraft into operation.*

We are beginning to work on integrating them operationally, so the pilot requirements, the airline operating requirements, and then were also beginning to work on the air space integration as well. . . . So we think that’s going to be a very important area over the next few years, and we see that as we solve the problems with small UAS, and beyond visual line of site, we’ll be turning more and more of our attention to these urban air mobility.

FAA and DOT

Federal Aviation Administration (Large UAS)

- Special Airworthiness Certificate (SAC)
- FAA Order 8130.34D
- Proposed operation does not present an unreasonable safety risk
- Certification for research and development

Department of Transportation

- Certificate of public convenience and necessity (or exemption)
- Streamlined procedures for UAS operators proposing to delivery “goods” as an “air taxi.”

State and Local

Roy Cooper, the North Carolina Governor, said, "We are proud to have the first autonomous aerial vehicle flying in North America, in North Carolina. . . . It's taking off. North Carolina has become the pilot that can help move this kind of business forward. We are excited about that."

North Carolina hosts first U.S. flight of EHang pilotless air taxi



SECTION 06

WAY ABOVE THE ROAD



Space Tourism



SpaceX's new space tourism offer: 5-day flight in Crew Dragon capsule

BUSINESS

Virgin Galactic Plans to Resume Space-Tourism Sales

Company backed by Richard Branson says it has secured 20 of 29 necessary approvals from FAA

1202269293

Space Tourism

SpaceX tourist trips to space station reportedly to cost \$55M each

Axiom Space signed a contract with Elon Musk's rocket company, and could bring tourists to space in 2021.



Informed Consent

- Commercial Space Launch Amendments Act of 2004 and regulations adopted on December 15, 2006 by the Federal Aviation Administration (FAA): *“The FAA is establishing requirements for human space flight as required by the Commercial Space Launch Amendments Act of 2004, including rules on crew qualifications and training, and informed consent for crew and space flight participants. The requirements should provide an acceptable level of safety to the general public and ensure individuals on board are aware of the risks associated with a launch or re-entry. The rule also applies existing financial responsibility and waiver of liability requirements to human space flight and experimental permits. Experimental permits are the subject of a separate rulemaking”*.

Informed Consent

- The state of New Mexico, from which Virgin Galactic will operate, has developed a law on “*informed consent for spaceflight*”:
 - “*Civil immunity for space flight entities*” that “*a space flight entity is not liable for a participant injury resulting from the risks of space flight activities, provided that the participant has been informed of the risks of space flight activities as required by federal law pursuant to federal law and this article, and the participant has given his informed consent that he is voluntarily participating in space flight activities after having been informed of the risks of those activities as required by federal law and this article*”.

Source: New Mexico Expanded Space Flight Informed Consent Act

SECTION 07

ANYWHERE AND EVERYWHERE



Robotic Exoskeletons, Like This One, Are Getting More Practical

By Jason Dorrier - Dec 18, 2019  6,815



587579231

Regulatory Implications

- Department of Labor: Occupational Safety and Health Administration (**OSHA**)
 - Guidelines for Robotics Safety (STD 01-12-002-PUB 8-1.3) (1987)
 - Technical Manual TED 01-00-015, Section IV (1999)
 - U.S. Department of Labor Signs Alliance with Robotic Industries Association and NIOSH to Improve Worker Protections in Emerging Tech Industry (November 2, 2017)
- Americans with Disabilities Act (**ADA**)
 - Employers are required to provide reasonable accommodations to qualified employees with disabilities
 - Generally, this means providing an accommodation that does not cause an undue hardship to the employer's operations.

Telepresence in the Workplace



The role of telepresence robotics in workforce inclusion

Peter Hirst 8:00 pm PDT • July 2, 2016

 Comment

Explosive Growth of Remote Work Solutions

Microsoft Teams jumps 70 percent to 75 million daily active users

Microsoft Teams is getting closer to Zoom than many expected

By Tom Warren | @tomwarren | Apr 29, 2020, 6:02pm EDT

Zoom buys the identity service Keybase as part of 90-day security push

Keybase serves as a secure home for online identities

By Jacob Kastrenakes | @jake_k | May 7, 2020, 9:38am EDT

TECH

Verizon will buy video conferencing company BlueJeans

PUBLISHED THU, APR 16 2020-9:00 AM EDT | UPDATED THU, APR 16 2020-10:01 AM EDT

Lauren Feiner
@LAUREN_FEINER

SHARE    

Legal Implications

- ADA
- Labor and Employment
- Tax

Morgan Lewis Coronavirus/COVID-19 Resources

We have formed a multidisciplinary Coronavirus COVID-19 Task Force to help guide clients through the broad scope of legal issues brought on by this public health challenge.

Find resources on how to cope with the post-pandemic reality on our [NOW. NORMAL. NEXT. page](#) and our [COVID-19 page](#) to help keep you on top of developments as they unfold.

If you would like to receive a daily digest of all new updates to the page, please visit either resource page to [subscribe](#), and download our biweekly [COVID-19 Legal Issue Compendium](#).

Q&A AND DISCUSSION

Presenters and Guests



Joan Haratani
Partner, Litigation
San Francisco



Elizabeth Herrington
Partner, Litigation
Chicago

QUESTIONS?



Biography



Lucy Wang

San Francisco

T +1.415.442.1132

E lucy.wang@morganlewis.com

Lucy Wang has broad experience representing financial institutions and high-tech companies in complex and cross-border disputes. Lucy's practice focuses on securities and regulatory actions as well as a range of intellectual property and commercial litigation.

Connect with me on LinkedIn:

<https://www.linkedin.com/in/lucy-wang-679aa513/>

Biography



Kevin Benedicto

San Francisco

T +1.415.442.1340

E kevin.benedicto@morganlewis.com

Kevin Benedicto represents and advises clients in a variety of litigation matters. His areas of practice include complex litigation, cybersecurity and data privacy matters, securities investigations and litigation, business and corporate disputes, and toxic torts.

Connect with me on LinkedIn:

<https://www.linkedin.com/in/kevinbenedicto/>

Biography



Joan Haratani

San Francisco

T +1.415.442.1262

E joan.haratani@morganlewis.com

Over more than three decades, Joan Haratani has honed practical, goal oriented, strategic thinking and courtroom skills in high-exposure cases. A co-lead counsel on some of the largest mass tort litigations, Joan defends her clients in class actions, from product liability litigation, to complex licensing agreements, to trade secret indemnity issues.

Connect with me on LinkedIn:

<https://www.linkedin.com/in/joan-haratani-b229761>

Biography



Elizabeth Herrington

Chicago

T +1.312.324.1445

E beth.herrington@morganlewis.com

Elizabeth (“Beth”) Herrington focuses her practice on complex commercial and class action litigation across the United States, including management of multi-jurisdictional related litigation. Beth regularly represents clients in high-exposure lawsuits that involve fraud, regulatory issues, privacy claims, contract claims, tax, and trade secret theft.

Connect with me on LinkedIn:

<https://www.linkedin.com/in/bethherrington/>

THANK YOU

© 2020 Morgan, Lewis & Bockius LLP

© 2020 Morgan Lewis Stamford LLC

© 2020 Morgan, Lewis & Bockius UK LLP

Morgan, Lewis & Bockius UK LLP is a limited liability partnership registered in England and Wales under number OC378797 and is a law firm authorised and regulated by the Solicitors Regulation Authority. The SRA authorisation number is 615176.

Our Beijing and Shanghai offices operate as representative offices of Morgan, Lewis & Bockius LLP. In Hong Kong, Morgan Lewis operates through Morgan, Lewis & Bockius, which is a separate Hong Kong general partnership registered with The Law Society of Hong Kong as a registered foreign law firm operating in Association with Luk & Partners. Morgan Lewis Stamford LLC is a Singapore law corporation affiliated with Morgan, Lewis & Bockius LLP.

This material is provided for your convenience and does not constitute legal advice or create an attorney-client relationship. Prior results do not guarantee similar outcomes. Attorney Advertising.

Our Global Reach

Africa
Asia Pacific
Europe
Latin America
Middle East
North America

Our Locations

Abu Dhabi
Almaty
Beijing*
Boston
Brussels
Century City
Chicago
Dallas
Dubai
Frankfurt
Hartford
Hong Kong*
Houston
London
Los Angeles
Miami
Moscow
New York
Nur-Sultan
Orange County
Paris
Philadelphia
Pittsburgh
Princeton
San Francisco
Shanghai*
Silicon Valley
Singapore*
Tokyo
Washington, DC
Wilmington

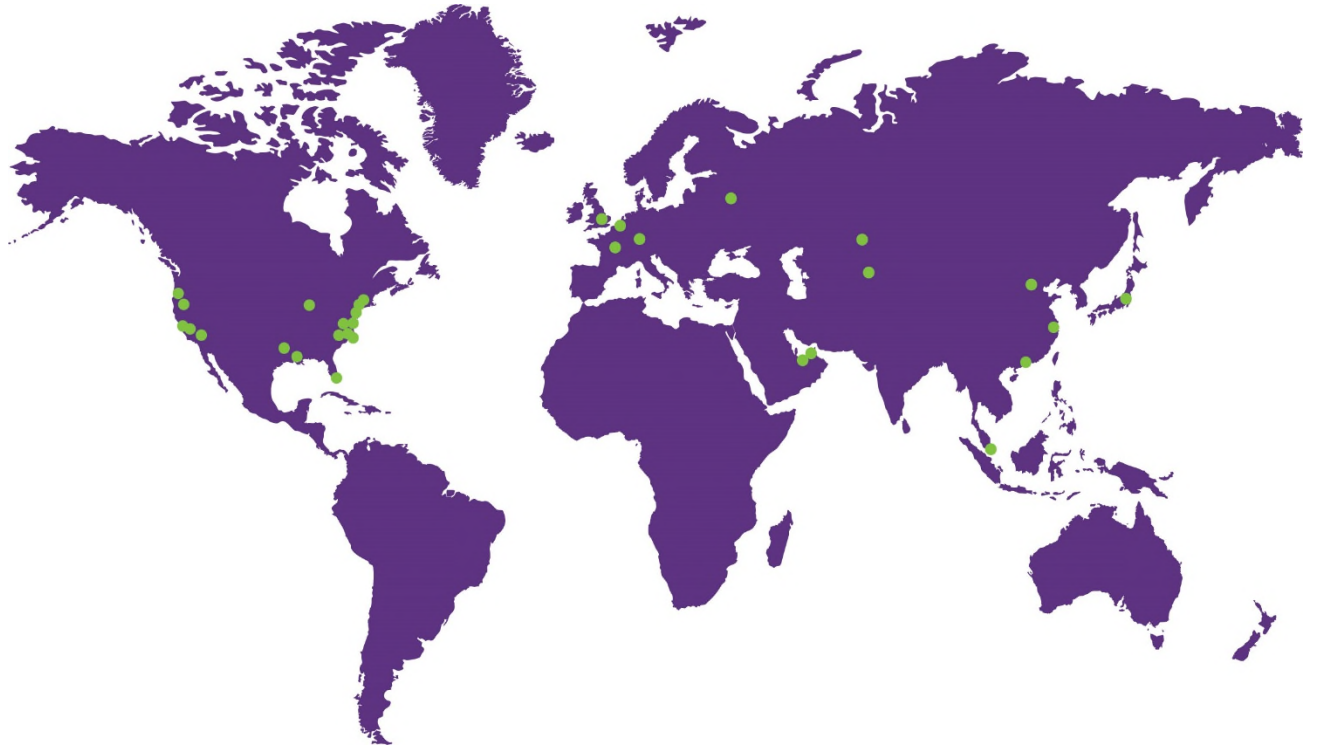

Morgan Lewis

*Our Beijing and Shanghai offices operate as representative offices of Morgan, Lewis & Bockius LLP. In Hong Kong, Morgan Lewis operates through Morgan, Lewis & Bockius, which is a separate Hong Kong general partnership registered with The Law Society of Hong Kong as a registered foreign law firm operating in Association with Luk & Partners. Morgan Lewis Stamford LLC is a Singapore law corporation affiliated with Morgan, Lewis & Bockius LLP.